

BIN RACK WITH METAL SHELVES

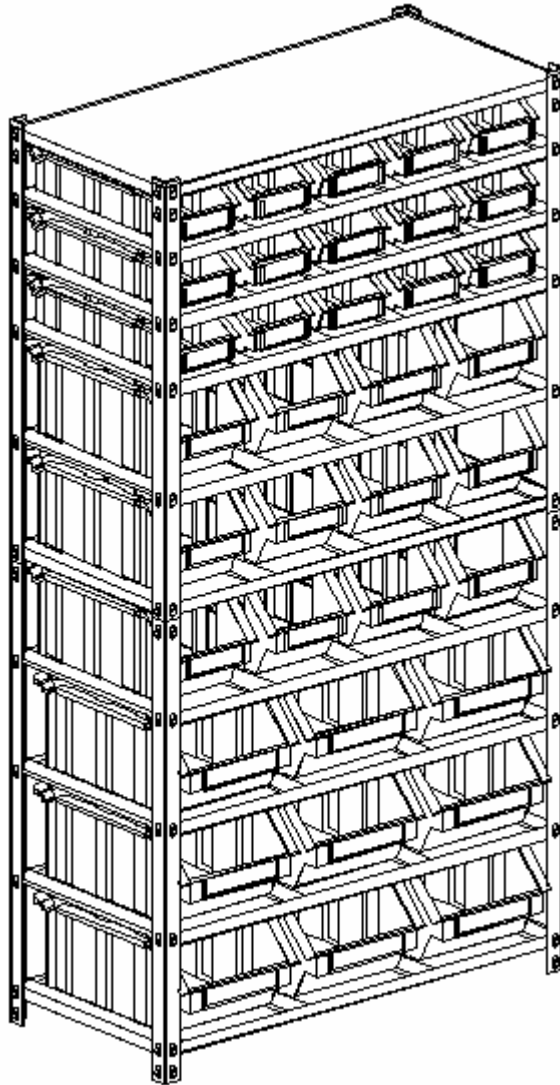

"ADULT ASSEMBLY REQUIRED DUE TO THE PRESENCE OF SMALL PARTS, SHARP POINTS, SHARP EDGES"



Organize your life.

Please call for replacement parts or assistance: 1-866-942-5362

Pacific Standard Time: 8:30 am - 4:30 pm Monday to Friday

Whalen Storage

Factory # 11482

Page # 1

Parts List

Please read completely through the instructions and verify that all parts listed are present before beginning assembly.



A-Long Double Rivet Beam (6)



B-Short Double Rivet Beam (6)



C-Long Single Rivet Beam (14)



D-Bottom Post (4)



E-Top Post (4)



F- Post Cap (4)



G-Top Flat Metal Shelf (1)

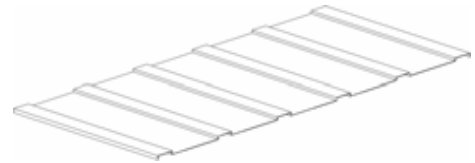

H- Metal Shelf for Small Bin (3)

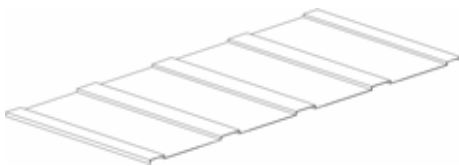

I- Metal Shelf for Med. Bin (3)

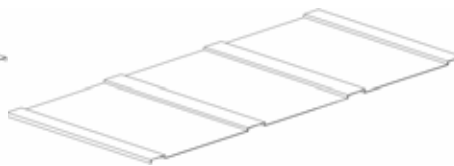

J- Metal Shelf for Big Bin (3)

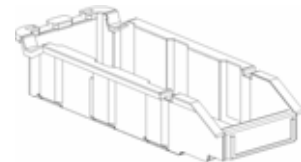

K-Small Bin & Paper Label (15)

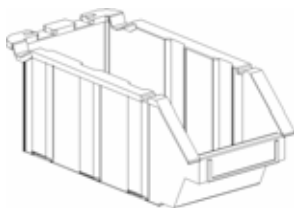

L- Medium Bin & Paper Label (12)

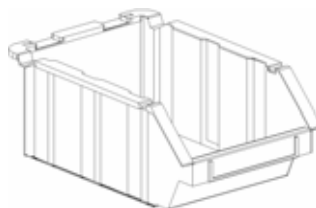

M- Large Bin & Paper Label (9)



Tipping Restraint Hardware Kit (2)
(Included inside white bag)

Tool Required: Rubber Mallet, Phillips Screwdriver, Mallet, Power Drill,

Please call for replacement parts or assistance: 1-866-942-5362

Whalen Storage

Factory # 11482

Page # 2

3/8" Drill Bit

Assembly Instructions

Note: Make sure all the rivets lock in place before using the Bin Rack.

1. Unpack the unit and confirm that you have all the hardware and required parts as listed.
2. Pick up one Short Double Rivet Beam (part B) and attach to the Post (part D) by inserting the two rivets in one end of the Beam into the bottom holes of the Post, as shown in detail#1. When inserting rivets into the holes you will be required to hit the beams with a rubber mallet to make them lock in place as shown in detail #A.
3. Now Attach another Post (part D) at the other end of the Short Double Rivet Beam, as shown in detail #1.

Note: Make sure that the thin edge of all the Beams is point up and the thick edge is point down when assembling into the posts and don't hit too hard for avoiding any damage or bending of the be

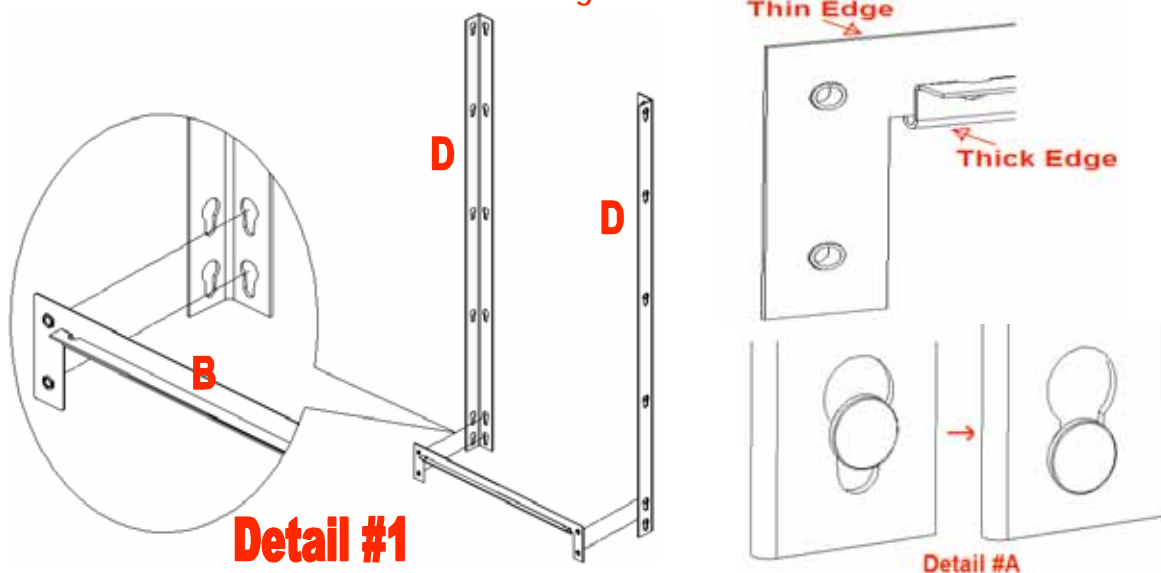

4. Attach two Long Double Rivet Beams (part A) to the other bottom holes of the Post as shown in detail#2.
5. Repeat step 2 & 3 to attach two more Posts to another Short Double Rivet Beam (part B) and attach to the other end of the two Long Double Rivet Beams (part A), as shown in detail #2.

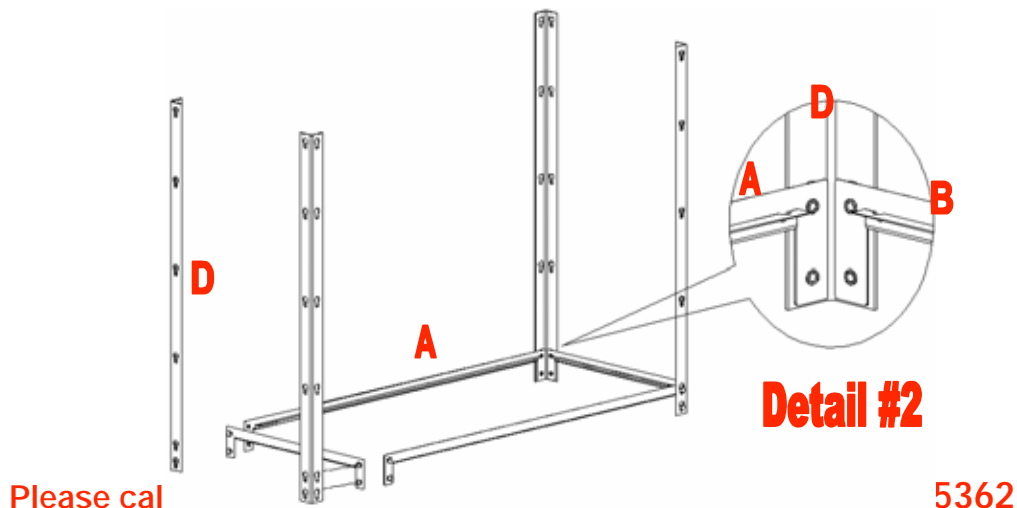

B Assembly Instructions

- Place one Metal Shelf for Big Bin (part J) on top of the set of Beams, tap with rubber mallet the ends of the Shelf to allow it all the way in. Make sure the Metal Shelf is leveled and centered to allow the Plastic Bins easy way out and not will hit the post. As shown in detail #3A.

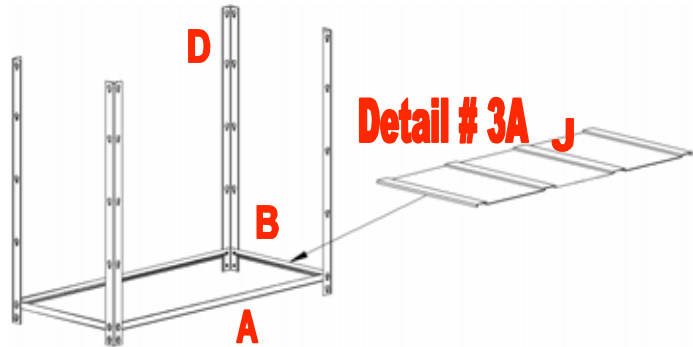

- Attach from one Post to another Post with one Long Single Rivet Beam (part C), at the 3rd hole from the bottom of the Post (or 1 hole from the last set of beams), see detail #3B.
- Repeat at the other side with another Beam at the same level as the last. Place one Metal Shelf for Big Bin (part J) on top of the Beams. See detail #3B.

Note: Tap with rubber mallet the ends of Metal Shelf to make sure it center and goes all the way in.

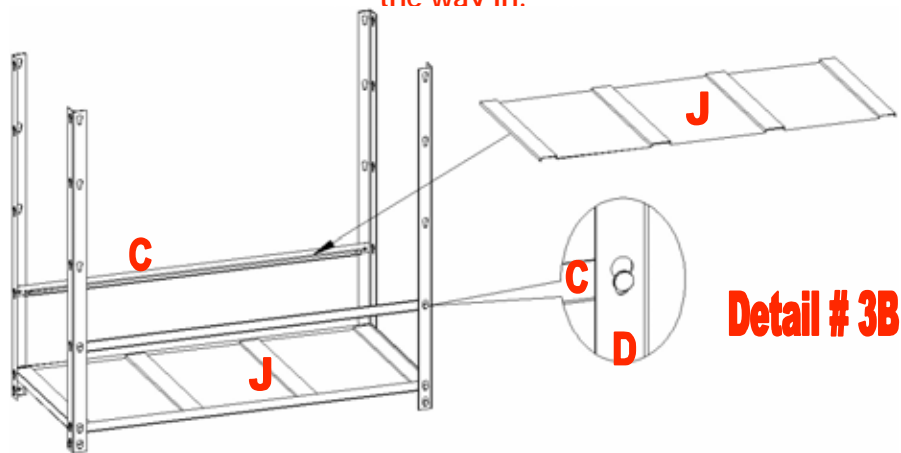

- Repeat steps 7 & 8 with another set of Single Rivet Beams on the 4th hole from the bottom of the post. See detail #4.

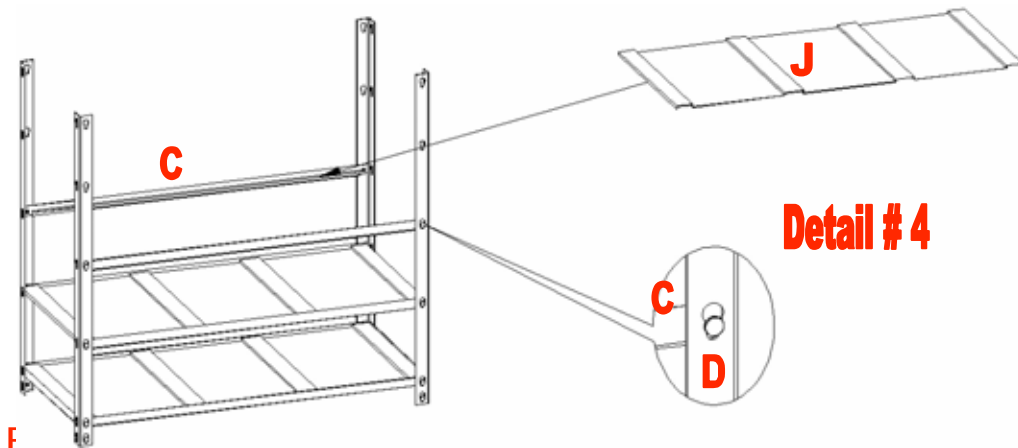

Assembly Instructions

10. Repeat steps 7 & 8 with another set of Single Rivet Beams on the 5th hole from the bottom of the post, as shown in detail #5. This only applies to Metal Shelf For Med. Bin (part I).

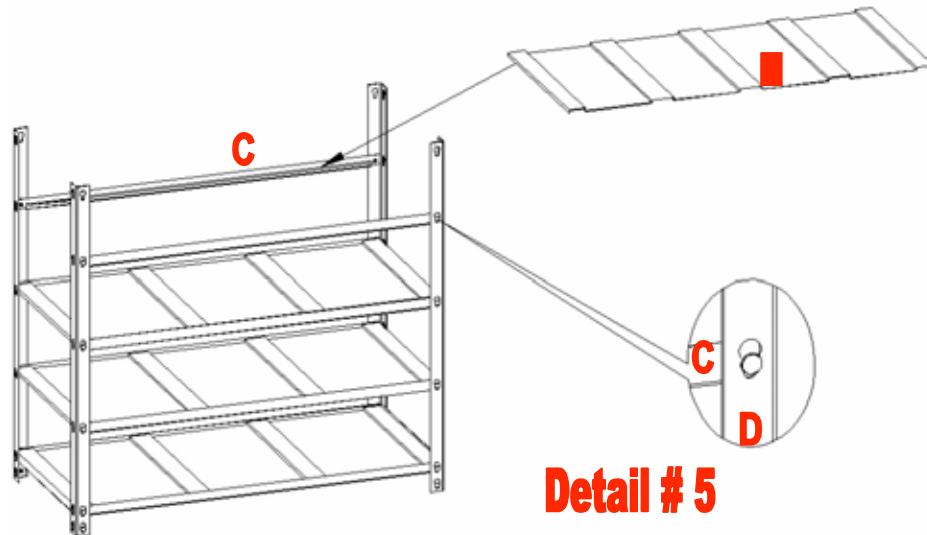

11. Take one Post and attach to the bottom hole with one Short Double Rivet Beam (part B) by using the top rivet of the Beam for the Post hole; make sure that the rivets are locked in place. See detail #5A.
12. Attach one Post to the other end of the Beam, as shown in detail #5A.
13. Now attach to the top of both Posts with another Short Double Rivet Beam. See detail #5A.
14. Repeat steps 11 thru 13 to make another set.

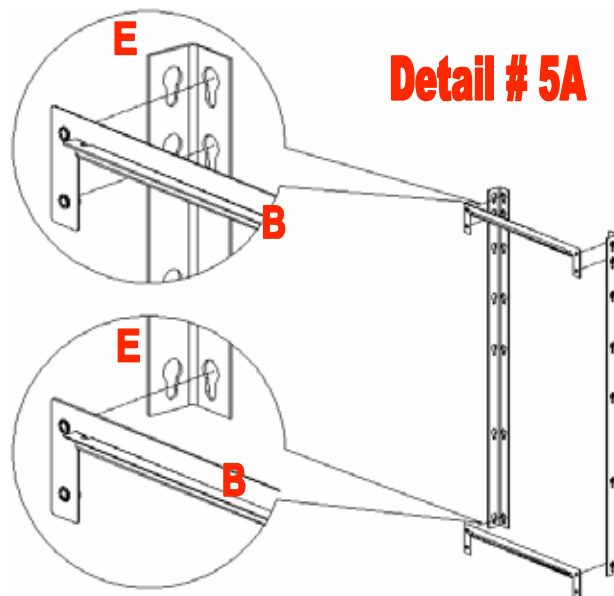

Please call for replacement parts or assistance: 1-866-942-5362

Whalen Storage
Factory # 11482
Page # 5

Assembly Instructions

15. Now attach one set of the last assembly (from step 11th to 13th) on top of the Posts by attaching the bottom rivet of the Beam to the bottom Post as shown in detail below.

Repeat at the other side. See detail #6.

16. Now repeat step 15th to attach the other set.

17. Attach two Long Double Rivet Beams (part A) to the long sides, use the top rivet of the beam with the top post and the bottom rivet with the top hole of the bottom post, as shown in detail #6. Place the Metal Shelf (part I) on top of Beams.

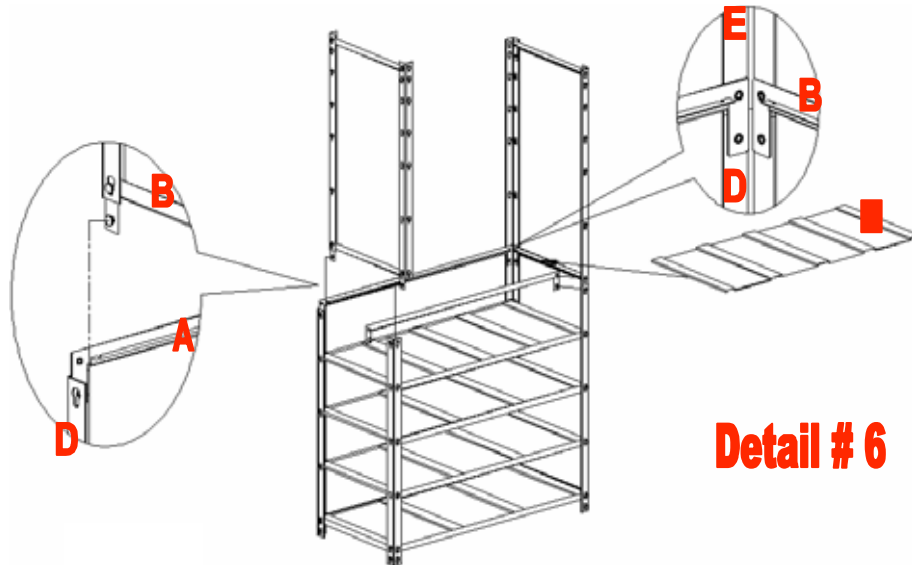

Detail # 6

18. Repeat steps 7 & 8 with another set of Single Rivet Beams on the 8th hole from the bottom of the post (or 1 hole from the last set of beams). Place the Metal Shelf (part I) on top of the beams. See detail #7.

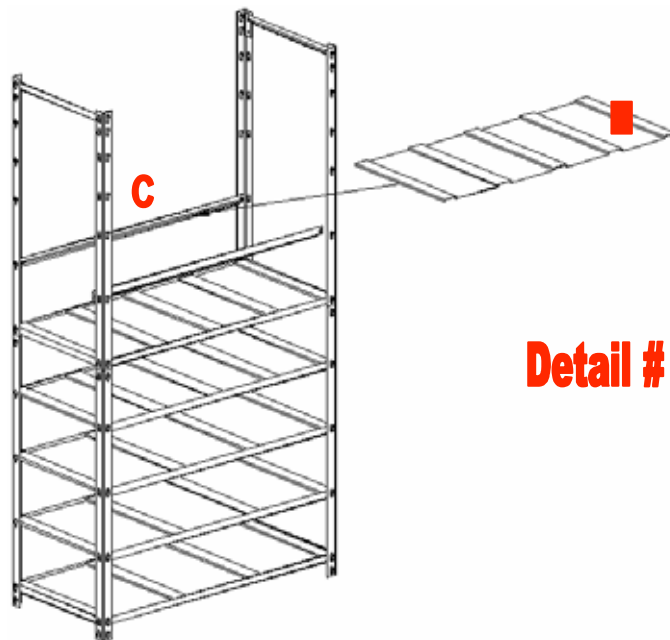

Detail # 7

Please call for replacement parts or assistance: 1-866-942-5362

Whalen Storage
Factory # 11482

Page # 6

Assembly Instructions

19. Repeat steps 7 & 8 with another set of Single Rivet Beams on the 9th hole from the bottom of the post (or 1 hole from the last set of beams). Place the Metal Shelf (part H) on top of the beams. See detail #8.

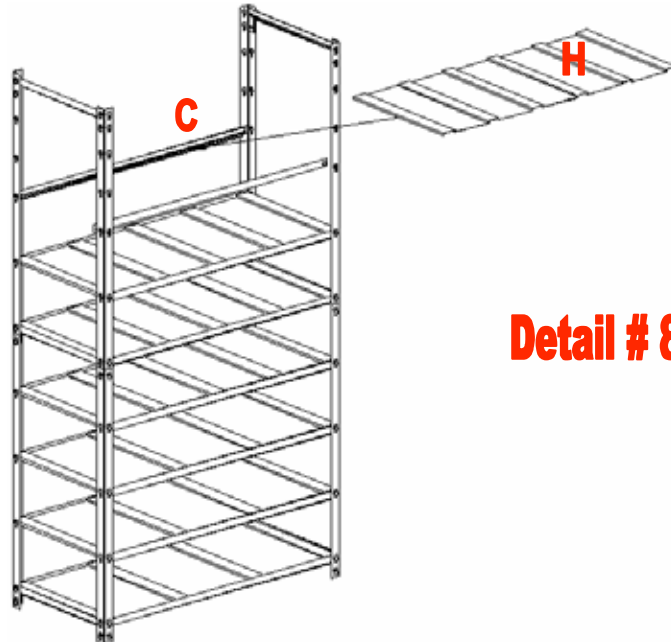

Detail # 8

20. Repeat steps 7 & 8 with another set of Single Rivet Beams on the 10th hole from the bottom of the post (or 1 hole from the last set of beams). Place the Metal Shelf (part H) on top of the beams. See detail #9.

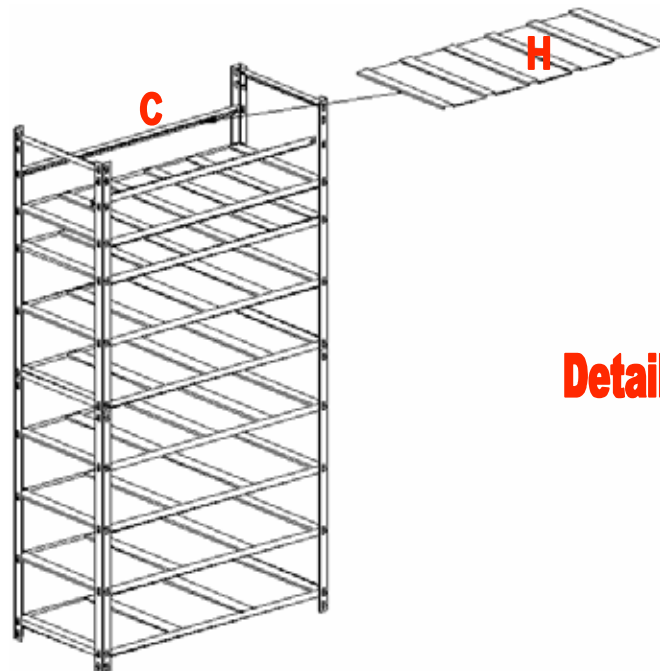

Detail # 9

Please call for replacement parts or assistance: 1-866-942-5362

Whalen Storage

Factory # 11482

Page # 7

Assembly Instructions

21. Repeat last step with another set of Single Rivet Beams on the 11th hole from the bottom of the post (or 1 hole from the last set of beams). Place the Metal Shelf (part H) on top of the beams. See detail #10.

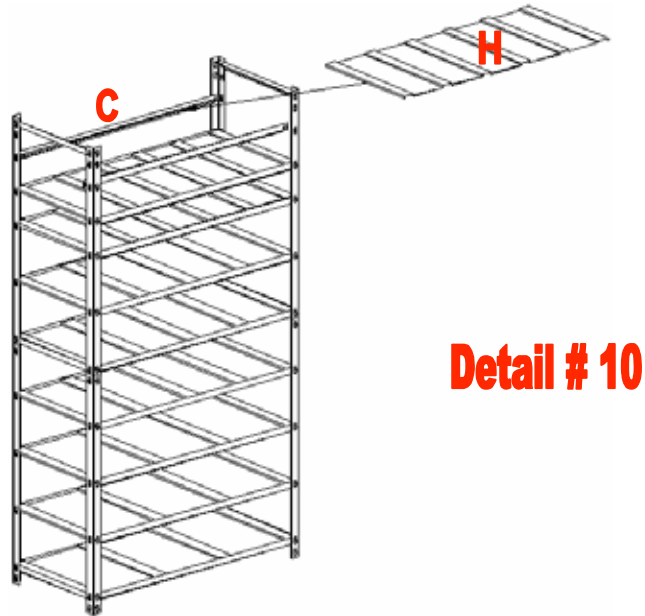

22. Now place a set of Double and Single Double Rivet Beams at the top of the Posts as shown in detail #11. Place the Top Flat Metal Shelf (part G)
23. Insert the Post Caps (part F) as shown in detail #11.

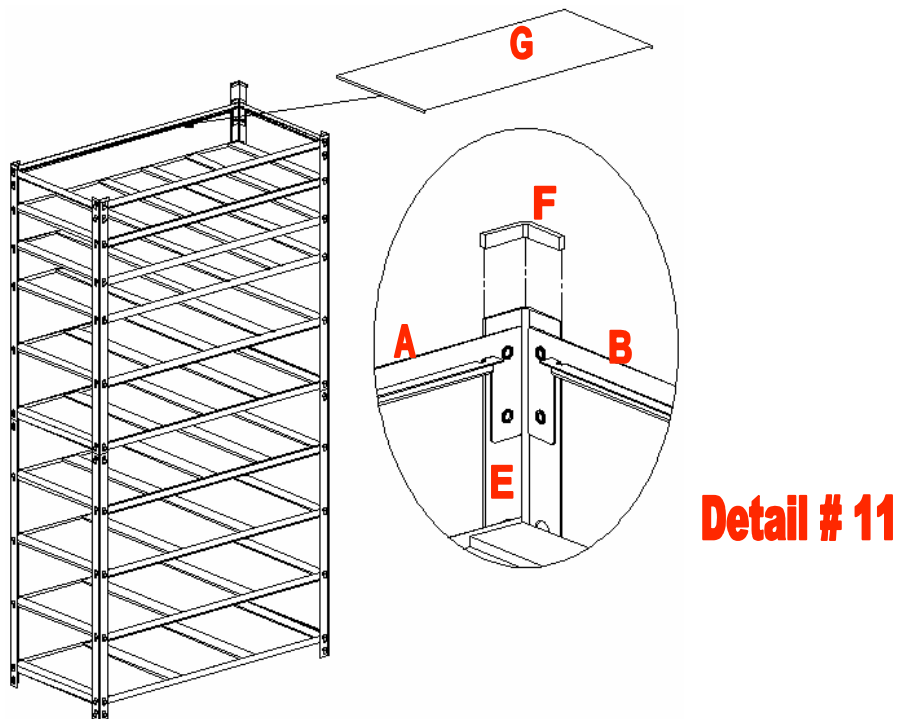

Please call for replacement parts or assistance: 1-866-942-5362

Whalen Storage
Factory # 11482
Page # 8

Assembly Instructions

24. Proceed to insert the Small, Medium and Large Bins (part K, L & M). See detail #12.

Note: To install the bins, they must be tilted upward to allow the raised sections in the back of the bin to be inserted under the beam. Once raised sections have been inserted under the beam, lower the bin to the level position and push into place. The raised sections help prevent the bins from pulling out completely during use.

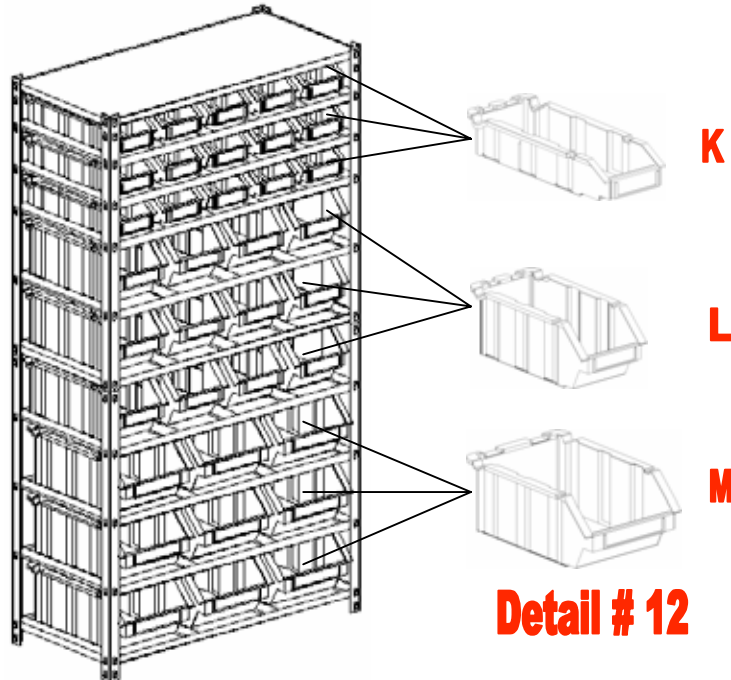

TIPPING RESTRAINT HARDWARE

Note: We have included two Tipping Restraint Hardware bags for this Unit.

When properly installed, this restraint can provide protection against the unexpected tipping of the Unit due to small tremors, bumps or climbing. We strongly recommend mounting this hardware to a wall stud and your Unit.

Please carefully read the instructions printed on the bag.

Note: You must install the Tipping Restraint Hardware with the unit in use to prevent any accidents or damage to the unit.

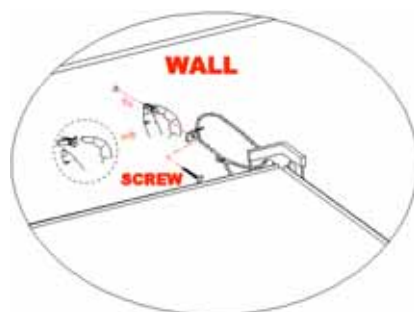

"Keep these instructions for further use"

Your assembly should now be complete. Thank you for your purchase.

Please call for replacement parts or assistance: **1-866-942-5362**

Whalen Storage

Factory # 11482

Page # 9