

48" BIN RACK WITH METAL SHELVES

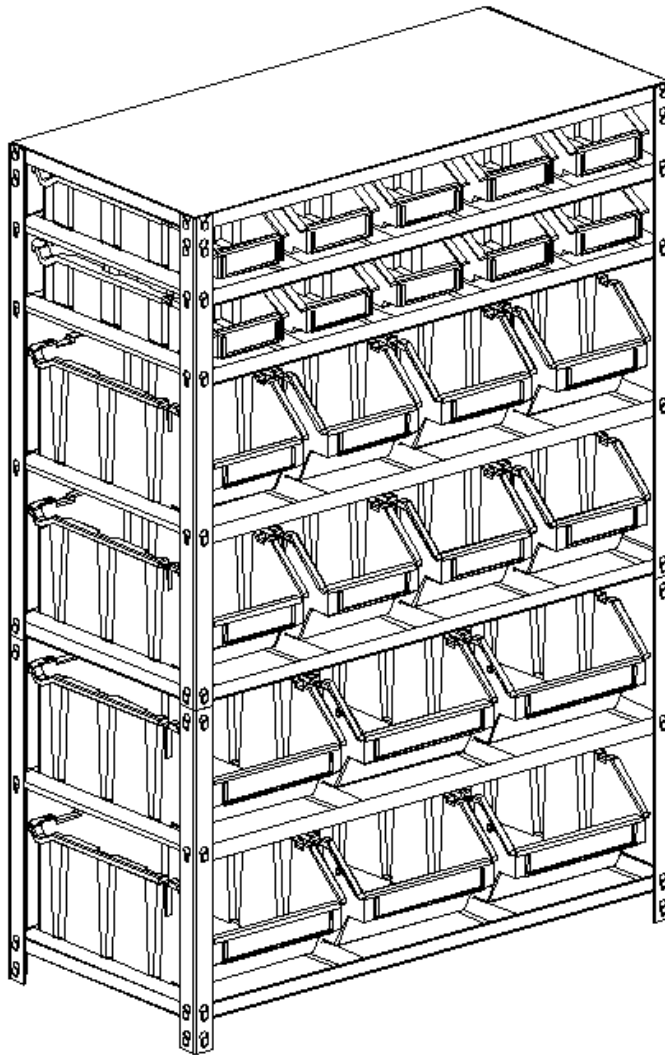

“ADULT ASSEMBLY REQUIRED DUE TO THE PRESENCE OF SMALL PARTS, SHARP POINTS, SHARP EDGES”



Organize your life.

Please call for replacement parts or assistance: 1-866-942-5362

Pacific Standard Time: 8:30 am – 4:30 pm Monday to Friday

Or visit our web site www.whalenstorage.com

Whalen Storage

Factory # 1566

Page # 1

Parts List

Please read completely through the instructions and verify that all parts listed are present before beginning assembly.



A- Long Double Rivet Beam (6-ea.)

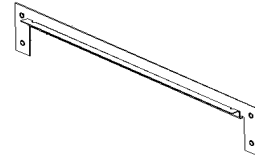

B- Short Double Rivet Beam (6-ea.)

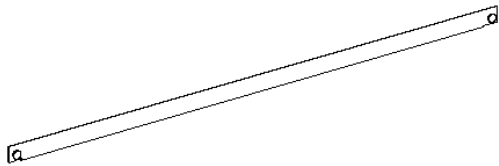

C- Long Single Rivet Beam (8- ea.)

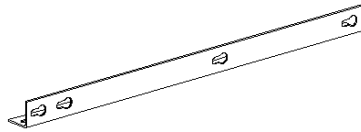

D- Bottom Post (4- ea.)

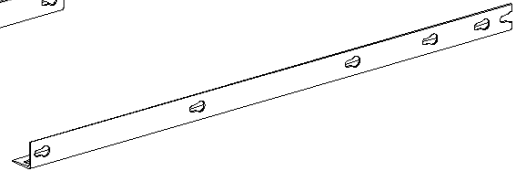

E- Upper Post (4- ea.)



F- Top Flat Metal Shelf (1-ea.)

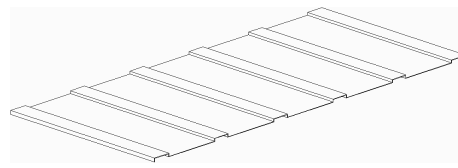

G- Metal Shelf for Small Bin (2-ea.)

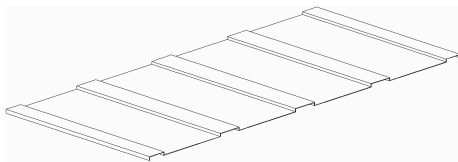

H- Metal Shelf for Medium Bin (2- ea.)

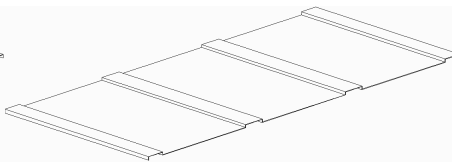

I- Metal Shelf for Big Bin (2- ea.)

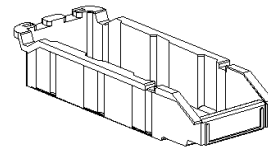

J- Small Bin (10- ea.)

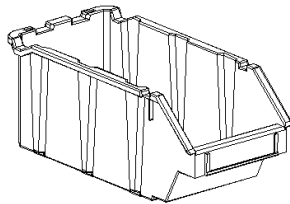

K- Medium Bin (8- ea.)

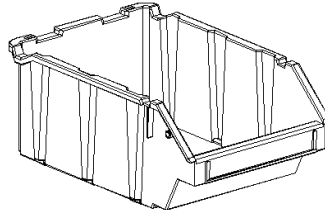

L- Large Bin (6- ea.)

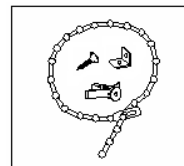

Tipping Restraint Hardware Kit (2-ea.)
(Included inside plastic bag)

Tool Required: Rubber Mallet, Phillips Screwdriver, Mallet, Power Drill, 3/8" Drill Bit

Please call for replacement parts or assistance: **1-866-942-5362**

Whalen Storage
Factory # 1566
Page # 2

Assembly Instructions

Note: Make sure all the rivets lock in place before using the Bin Rack. If you have any defective parts please do not use, improper installation may result in damage or injury.

1. Unpack the unit and confirm that you have all the hardware and required parts listed.
2. Pick up one Short Double Rivet Beam (part B) and attach to Bottom Post (part D) by inserting the two rivets in one end of the Beam into the bottom holes of the Post, as shown in detail#1. When inserting rivets into the holes you will be required to hit the beams with a rubber mallet to make them lock in place as shown in detail #A.
3. Now attach another Bottom Post (part D) at the other end of the Short Double Rivet Beam, as shown in detail #1.

Note: Make sure that the thin edge of all the Beams is point up and the thick edge is point down when assembling into the posts and don't hit too hard for avoiding any damage or bending of the beams. Use a cloth or wood block to protect the surface finish of the product when using a hammer

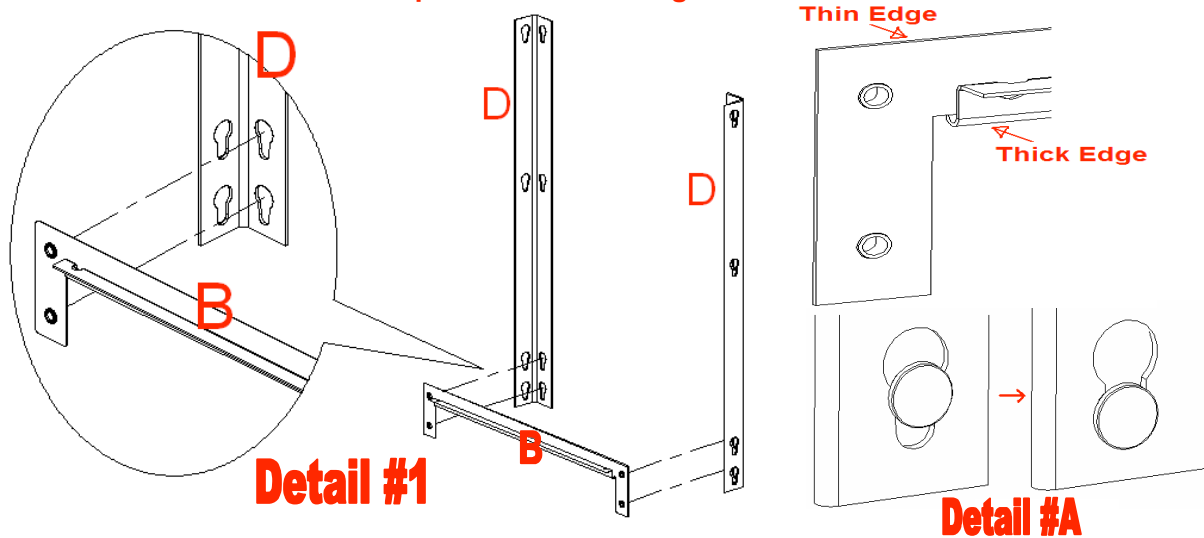

4. Attach two Long Double Rivet Beams (part A) to the other bottom holes of the Posts as shown in detail#2.
5. Repeat step 2 & 3 to attach the remaining Bottom Posts (part D) to another Short Double Rivet Beam (part B) and attach to the other end of the two Long Double Rivet Beams (part A), as shown in detail #2.

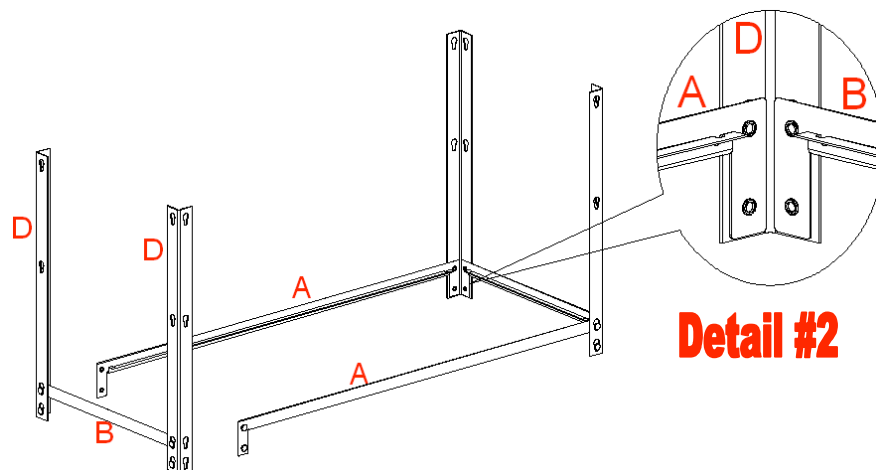

Please call for replacement parts or assistance: 1-866-942-5362

Whalen Storage
Factory # 1566
Page # 3

Assembly Instructions

- Place one Metal Shelf for Big Bin (part I) on top of the set of Beams, tap with rubber mallet the ends of the Shelf to allow it all the way in. Make sure the Metal Shelf is leveled and centered to allow the Plastic Bins easy way out and will not hit the post. See detail #2

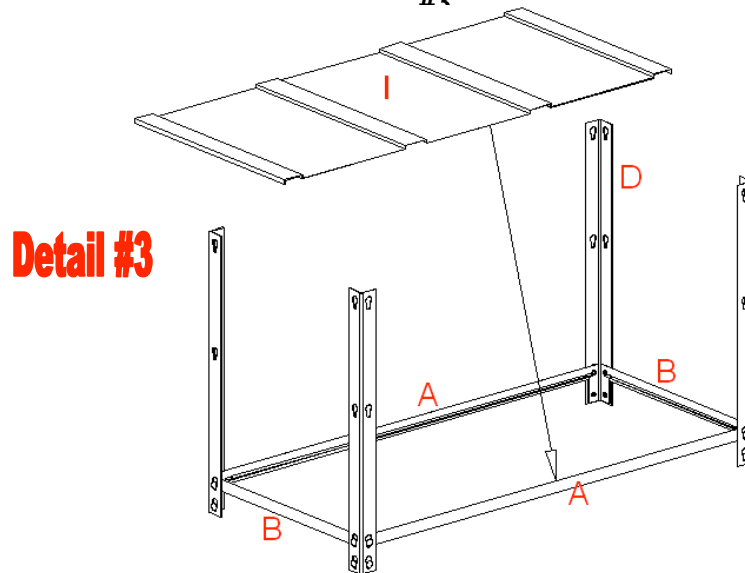

- Attach from one Post to another Post with one Long Single Rivet Beam (part C), at the 3rd hole from the bottom of the Post (or 1 hole from the last set of beams), see detail #4. Drive the rivets to the bottom of the keyhole by hitting the beam near the joint with a rubber mallet to lock the pieces together.
- Repeat at the other side with another Beam at the same level as the last. Place the other Metal Shelf for Big Bin (part I) on top of the Beams. See detail #4.

Note: Tap with rubber mallet the ends of Metal Shelf to make sure it center and goes all the way in

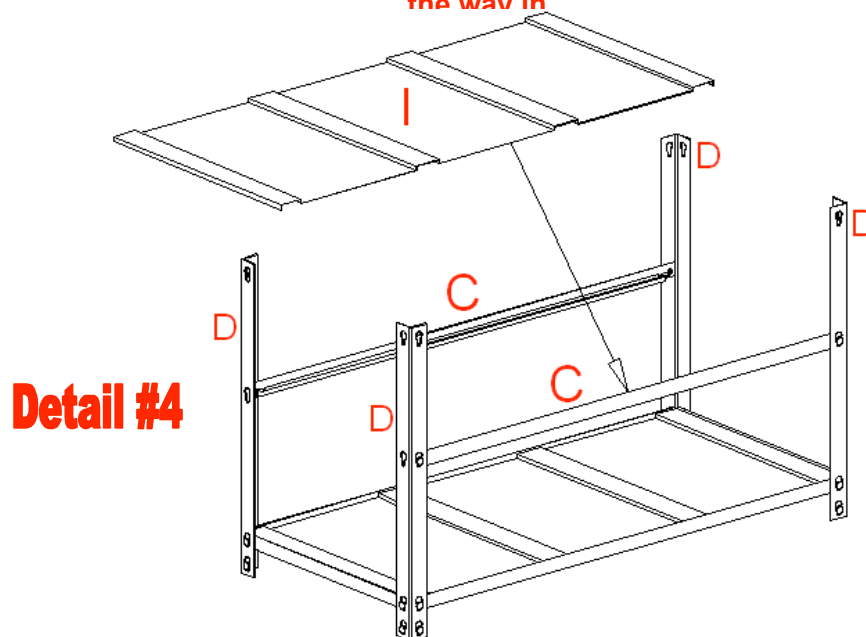

Please call for replacement parts or assistance: 1-866-942-5362

Whalen Storage

Factory # 1566

Page # 4

Assembly Instructions

9. Take one Upper Post (part E) and attach to the bottom hole one Short Double Rivet Beam (part B) by using the top rivet of the Beam for the Post keyhole; make sure that the rivets are locked in place. See detail #5.
10. Attach another Upper Post (part E) to the other end of the Beam, as shown in detail #5.
11. Attach at the top of both Upper Posts another Short Double Rivet Beam (part B). See detail #5.
12. Repeat steps 9 thru 11 to make another set.

Detail #5

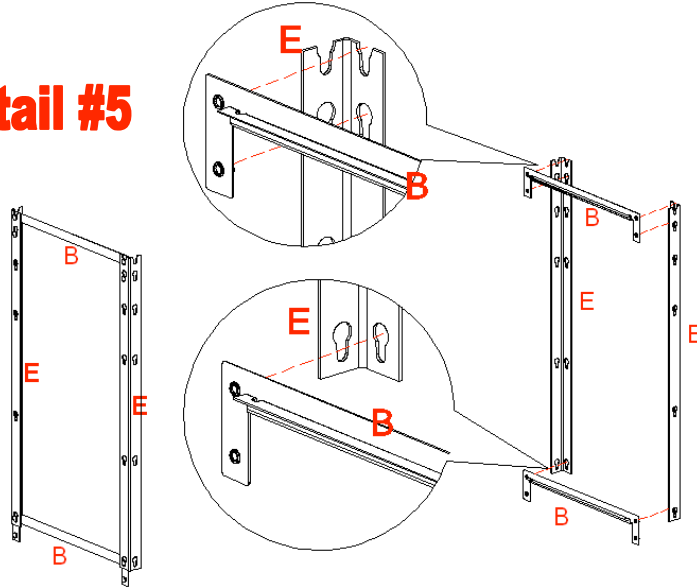

13. Now attach one set of the last assembly (from step 9th to 11th) on top of the Bottom Posts (part D) by attaching the bottom rivet of the Beam (part B) to the Bottom Post as shown in detail #6. Repeat the step at the other side.
14. Repeat step 13th to attach the other set.
15. Attach two Long Double Rivet Beams (part A) to the long sides, use the top rivet of the beam with the Upper Post and the bottom rivet with the top hole of the Bottom Post, as shown in detail #6. Place the Metal Shelf for Medium Bin (part H) on top of Beams.

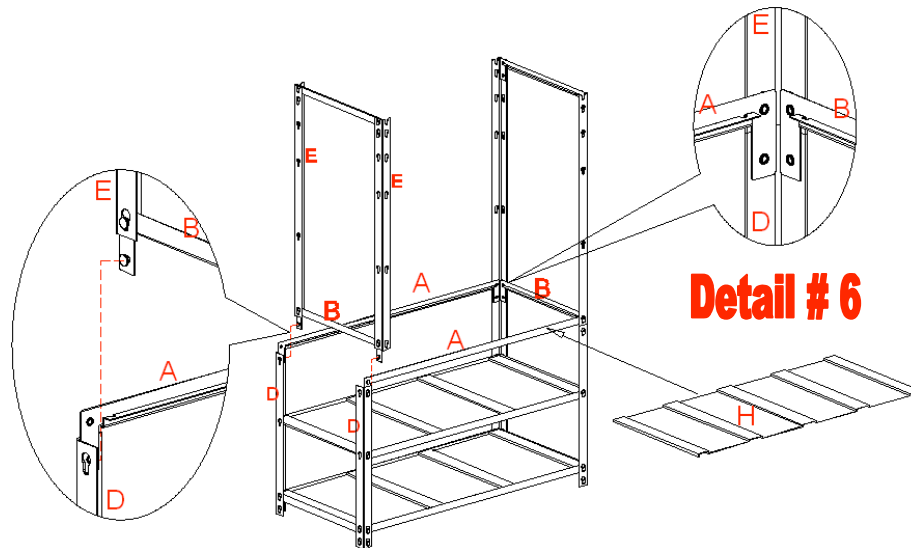

Please call for replacement parts or assistance: **1-866-942-5362**

Whalen Storage

Factory # 1566

Page # 5

Assembly Instructions

16. Repeat steps 7 & 8 with another set of Single Rivet Beams (part C) on the 6th hole from the bottom of the post (or 1 hole from the last set of beams). Place the Metal Shelf for Medium Bin (part H) on top of the beams. See detail #7.

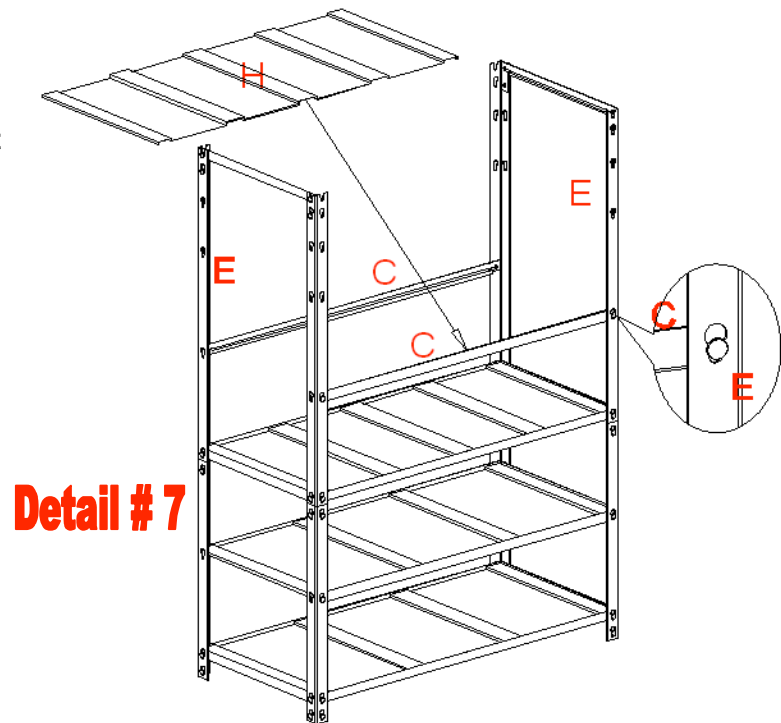

17. Repeat steps 7 & 8 with another set of Single Rivet Beams (part C) on the 7th hole from the bottom of the post (or 1 hole from the last set of beams). Place the Metal Shelf for Small Bin (part G) on top of the beams. See detail #8.

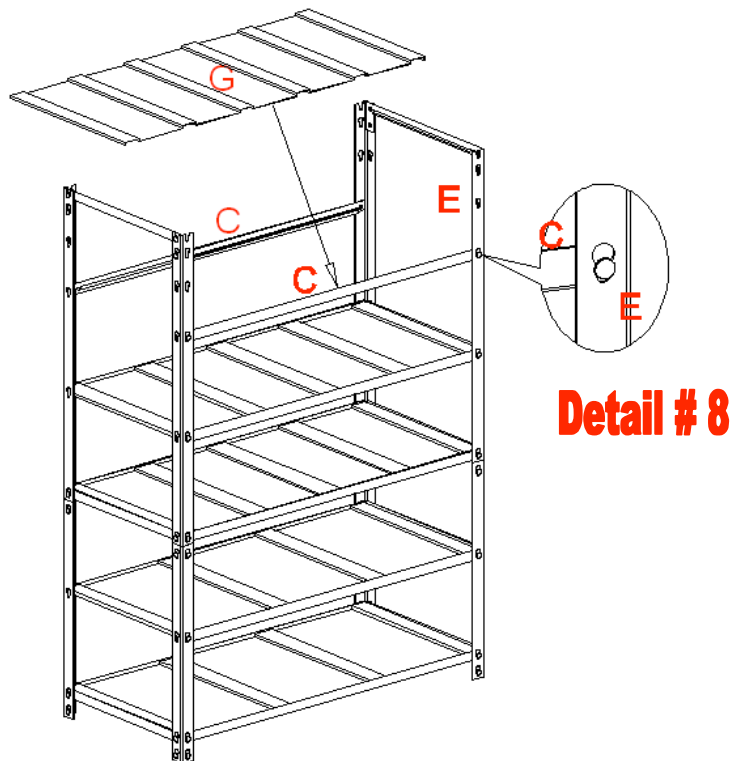

Please call for replacement parts or assistance: **1-866-942-5362**

**Whalen Storage
Factory # 1566
Page # 6**

Assembly Instructions

18. Repeat steps 7 & 8 with another set of Single Rivet Beams (part C) on the 8th hole from the bottom of the post (or 1 hole from the last set of beams). Place the Metal Shelf for Small Bin (part G) on top of the beams. See detail #9.

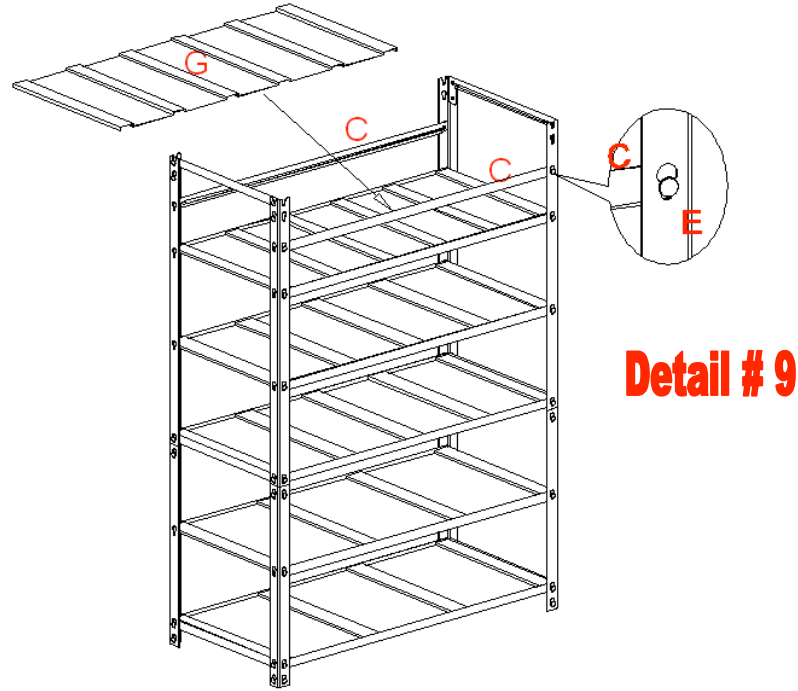

19. Now pick up a set of Double Rivet Beams (part A) and join into the top two keyholes of the Upper Posts (part E) as shown in detail #10. Drive the rivets to the bottom of the keyhole with a rubber mallet. Drop the Top Flat Metal Shelf (part F) onto place.

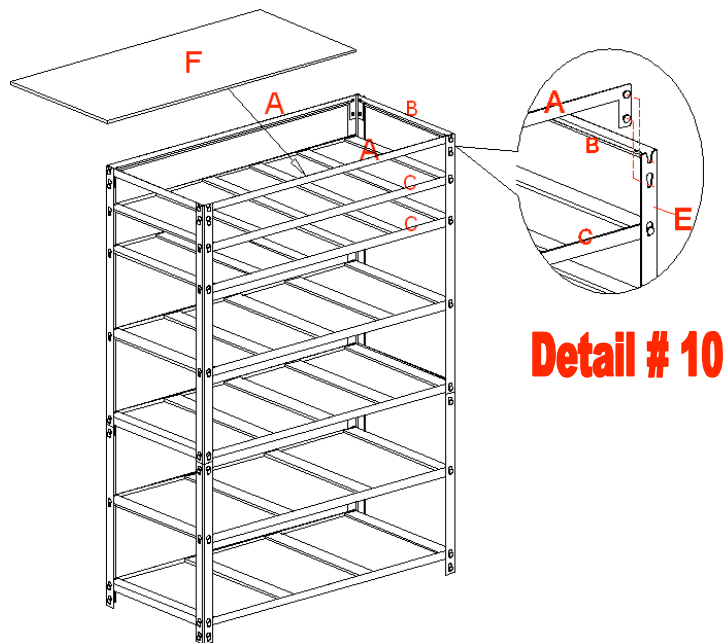

Please call for replacement parts or assistance: 1-866-942-5362

Whalen Storage
Factory # 1566
Page # 7

Assembly Instructions

20. Now insert the Small, Medium and Large Bins (part J, K & L) in place. See detail #11.

Note: To install the bins, they must be tilted upward to allow the raised sections in the back of the bin to be inserted under the beam. Once raised sections have been inserted under the beam, lower the bin to the level position and push into place. The raised sections help prevent the bins from pulling out completely during use.

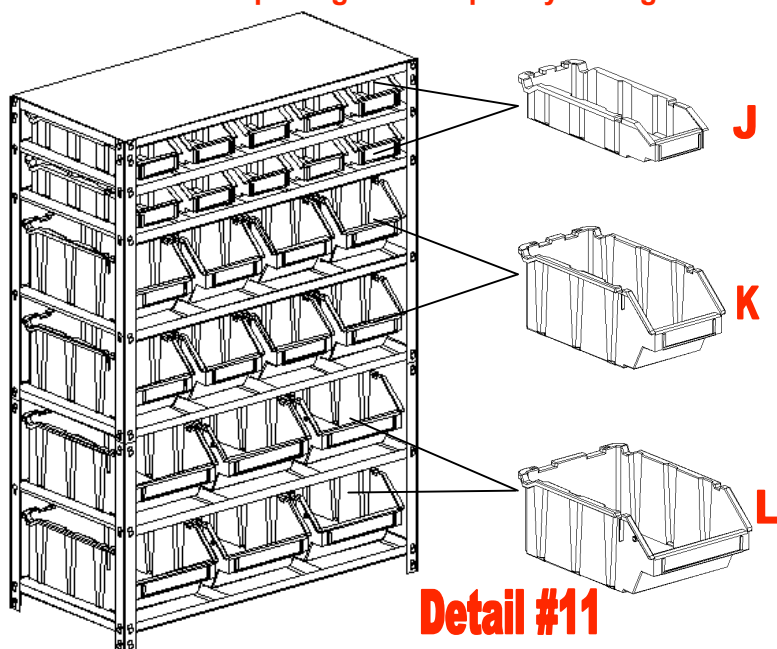

TIPPING RESTRAINT HARDWARE

Note: We have included two Tipping Restraint Hardware bags for this Unit.

When properly installed, this restraint can provide protection against the unexpected tipping of the Unit due to small tremors, bumps or climbing. We strongly recommend mounting this hardware to a wall stud and your Unit.

Please carefully read the instructions printed on the bag.

Note: You must install the Tipping Restraint Hardware with the unit in use to prevent any accidents or damage to the unit.

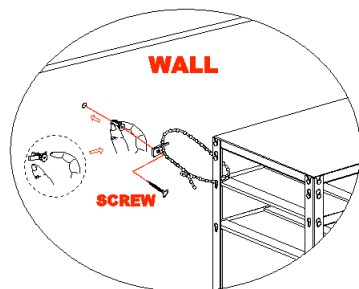

Organize your life.

Visit us on web: www.whalenstorage.com

“Keep these instructions for further use”

Your assembly should now be complete.

Thank you for your purchase.

Please call for replacement parts or assistance: 1-866-942-5362

Whalen Storage

Factory # 1566

Page # 8