

INDUSTRIAL RACK

WS7224WDD

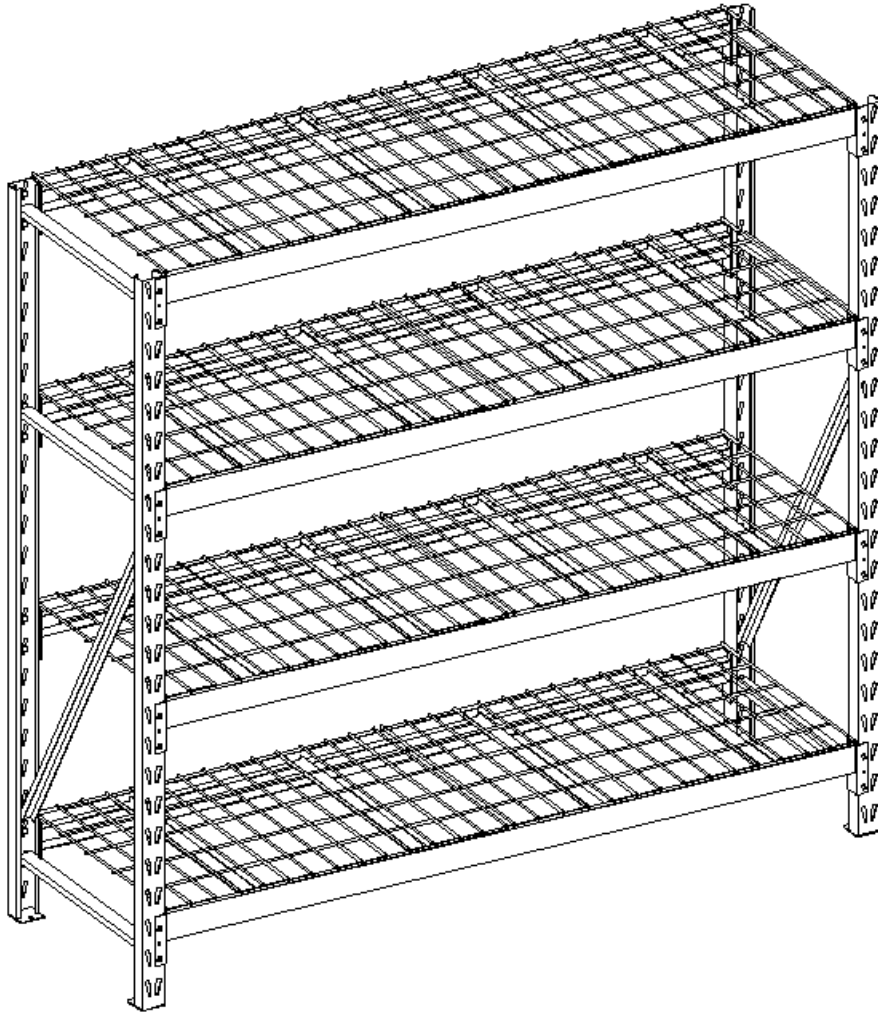

"ADULT ASSEMBLY REQUIRED DUE TO THE PRESENCE OF SMALL PARTS, SHARP POINTS, SHARP EDGES"



Organize your life.

Please call for replacement parts or assistance: 1-866-942-5362

Pacific Standard Time: 8:30 am – 4:30 pm Monday to Friday

Whalen Storage

Factory # 11296

Page # 1

Parts List

Please read completely through the instructions and verify that all parts listed are present before beginning assembly.

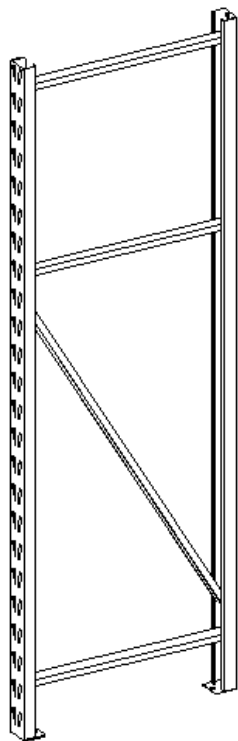

A- Upright Frame (2)



B- Cross Beam (8)

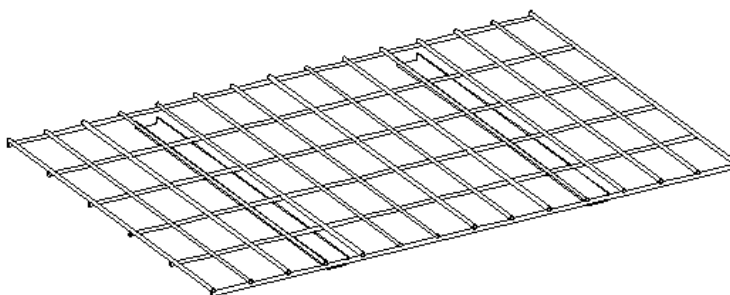

C- Wire Deck (8)

Tool Required: Rubber Mallet.

Please call for replacement parts or assistance: **1-866-942-5362**

Whalen Storage
Factory No. 11296

Page # 2

Assembly Instructions

Note: Make sure all the clips lock in place securely before using the unit, if you have any defective parts please do not use, improper installation may result on damage or injury.

1. Unpack the unit and lay parts out on floor.
2. Pick up one Cross Beam (part B) and attach to the Column of Upright Frame (part A) by inserting the two clips on the bracket of Cross Beam into the keyholes of the Column. You need to insert the clips starting from the outside and then tap down with rubber mallet to seat the beam into the column in place. See detail #1.

Note: Make sure the 3/4" narrow flange goes on top and don't hit too hard so you will not damage or bend the beams.

3. Now attach the other Upright Frame (part A) at the other end of the Cross Beam, make sure the clips are at the same level. **Ask the assistance of your friends.** As shown in detail #1.
4. Repeat last two steps to attach the other Cross Beam (part B) to the opposite two Columns. Make sure the two Cross Beams are at the same level.

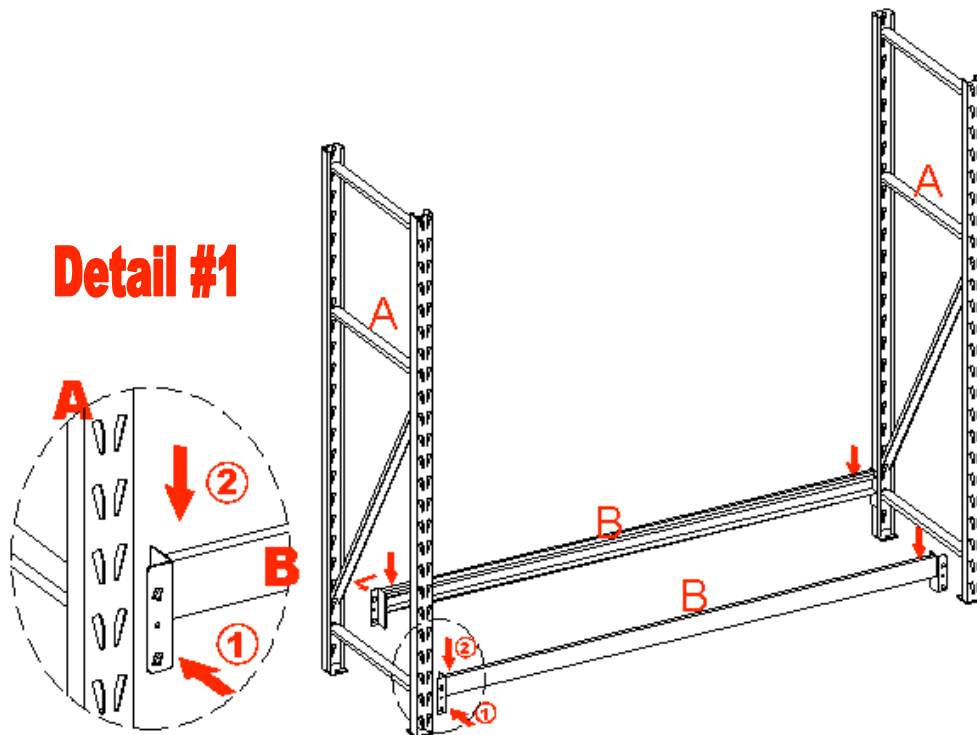

Please call for replacement parts or assistance: 1-866-942-5362

Whalen Storage
Factory No. 11296
Page # 3

Assembly Instructions

- Repeat steps 2 through 4 to attach next two set of Cross Beams (part B) at the same level to form the second and third shelf frame, as shown in detail #2.

Note: The columns are adjustable in 3" increment. You can adjust the wire deck shelves at your desired height.

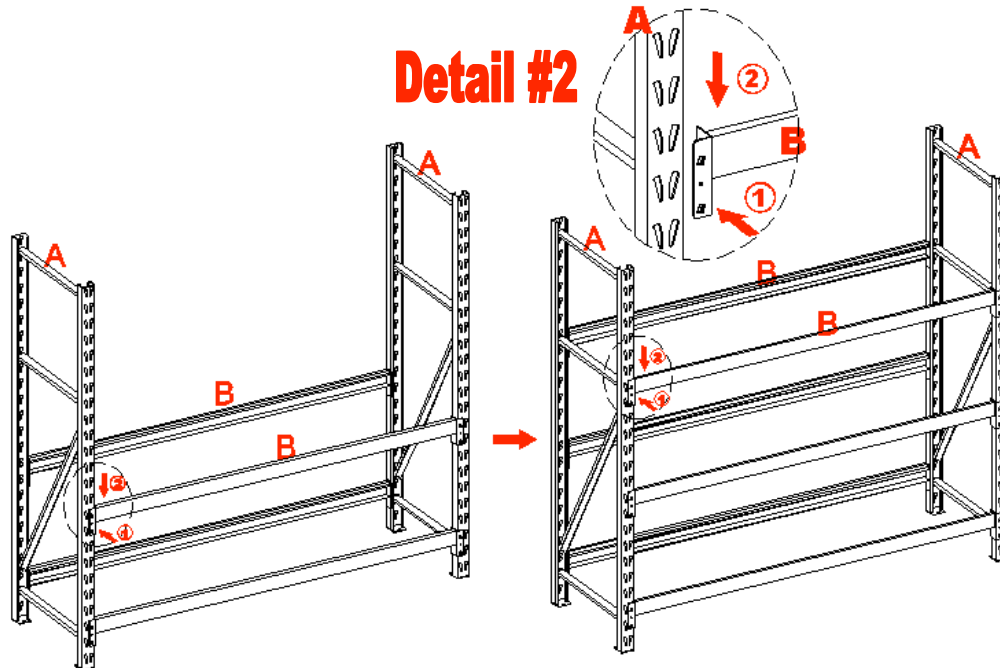

- To complete the frame assembly repeat steps 2 through 4 to attach the last two Cross Beams (part B) on the top two keyholes of Columns. as shown in detail #3.

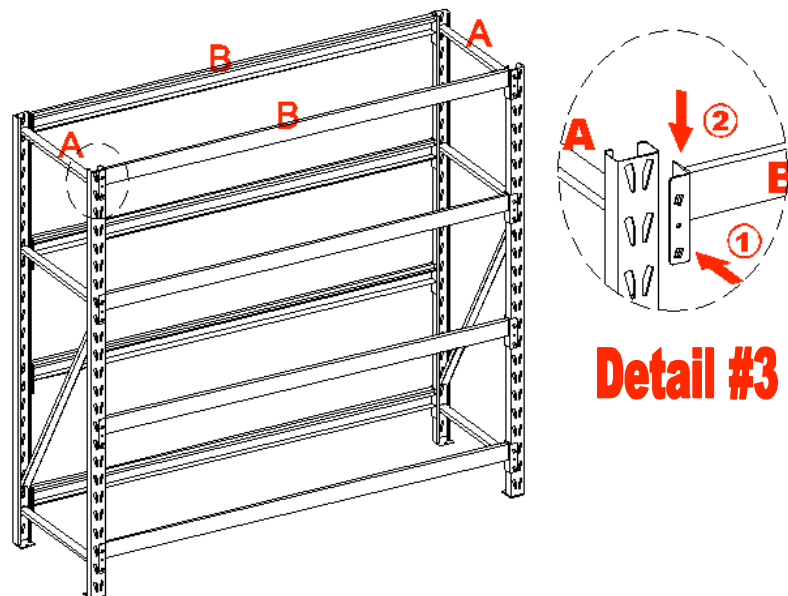

Please call for replacement parts or assistance: 1-866-942-5362

Assembly Instructions

- Drop the Wire Decks (part C) into top flange of the Cross Beams (part B). Make sure the wire decks seat properly between each set of Cross Beam and flush with each other. As shown in detail #4.

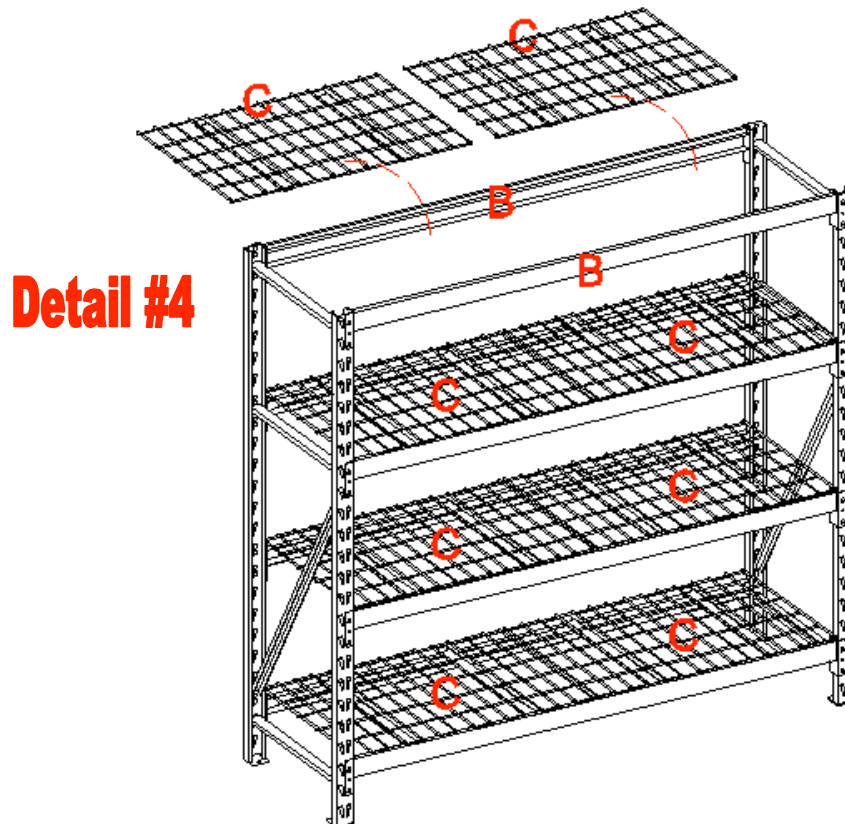

- Periodically inspect the unit to ensure beams are seated properly and brackets are firmly connected to the Columns. The Wire Deck maximum load 1764 LBS evenly distributed. Care should be taken not to overload the Wire Decks.

“KEEP THESE INSTRUCTIONS FOR FUTURE REFERENCE.”

**Your assembly should now be complete.
Thank you for your purchase.**



Please call for replacement parts or assistance: 1-866-942-5362

Whalen Storage
Factory No. 11296
Page # 5